

Physical Performance, Body Composition and Body Balance in Relation to National Ranking Positions in Young Polish Tennis Players

DOI: 10.2478/v10131-0011-z

Authors' Contribution:

A – Study Design
B – Data Collection
C – Statistical Analysis
D – Data Interpretation
E – Manuscript Preparation
F – Literature Search
G – Funds Collection

Mateusz Karnia^{1 (D,E,F)}, **Tomasz Garsztka**^{2 (B)},
Mateusz Rynkiewicz^{3 (B,E,F)}, **Tadeusz Rynkiewicz**^{3 (D,E)},
Piotr Żurek^{3 (B,E,F)}, **Marcin Łuszczuk**^{1 (C)}, **Ewelina Śledziwska**^{1 (D)},
Ewa Ziemann^{4 (A,B,C,D,E,F,G)}

¹ Jędrzej Sniadecki Academy of Physical Education and Sport in Gdansk, Poland

² Eugeniusz Piasecki Academy of Physical Education in Poznan, Poland

³ Eugeniusz Piasecki Academy of Physical Education in Poznan, Faculty of Physical Education in Gorzow Wlkp., Poland

⁴ Warsaw School of Social Sciences and Humanities, Department of Physiotherapy, Sopot, Poland

Key words: *physical performance, tennis, body composition, body balance, tennis ranking.*

Abstract

Background: *The purpose of this study was to determine the relationship between body composition, aerobic capacity and the balance in young tennis players at rest and during fatigue triggered by an endurance test. Moreover, we tried to find the correlation between the tennis ranking position and the balance.*

Material/Methods: *Well-trained 16 young tennis players (15 and 17 years old, singles national ranking 3-39, average training experience of 9 years) took part in this study. They were assigned to two groups according to their age – 15 TG and 17 TG. Participants completed the same battery of body composition, aerobic, and body balance assessments. Body balance measurement was repeated twice – before and after the aerobic assessment.*

Results: *The main finding of this study points out the body balance to be a motor ability influencing results achieved in the specific tennis drill. This connection was observed in both of the tested groups; however, it was particularly significant within 17 TG.*

Conclusions: *The presented study does not point out the main factor to focus on when conducting a career of a professional tennis player regardless of the numerous tests and measurements included in the analysis observed. Interesting correlations may suggest that for the players in a developmental age it is speed and balance that ought to be more intensively developed.*

Word count: 4291

Tables: 7

Figures: 3

References: 19

Received: September 2010

Accepted: November 2010

Published: December 2010

Address for correspondence:

Dr Ewa Ziemann

Warsaw School of Social Sciences and Humanities, 81-645 Sopot, Poland, ul. Polna 16/20

Phone: +48606-330-944, e-mail: ewa.ziemann@swps.edu.pl

Introduction

Tennis is a sport discipline with a growing number of players, estimated around 75 million people [1,2]. It is a type of sport characterized with short and intermittent efforts of an altering intensity and time, where numerous factors determine the achieved success. Some of them include human's morphological body build, motor abilities and efficiency of the energetic systems. Both motor abilities and physical capacity appear to be particularly significant due to the unpredictable time and weather situation of the tournaments. Since there are no time limitations of the matches, very often prolonged physical effort with high intensity is required from a player, as well as an ability to adjust to altering climate conditions such as high temperatures [3]. It has been recently noticed that a proper control of training ought to include balance as a motor ability. Nonetheless, only few studies so far have focused on a more inquisitive investigation of this issue. Still, attention is drawn to the fact that balance developed through appropriate training is a factor lowering the risk of some injuries [4,5]. What is more, it is an inseparable component of the footwork, which is the main determinant of proficient movement on a court [6]. Most studies focus on establishing the biomechanical model that would provide the best possible evaluation and analysis of the term in order to increase the efficiency of diagnostic methods as well as to choose suitable tests for skilled athletes [7]. It is particularly essential due to the fact that professional tennis has considerably evolved. Firstly, the game has become faster, where various changes of direction occur. Secondly, nowadays it involves players of a younger age, who undergo training with high intensity and workload. These evaluations indicate the necessity of a deeper analysis and assessment of both the physical capacity and motor abilities at every stage of the player's development. Such a study appears particularly vital as only few reports refer to the determination of balance in tennis players of developmental age [8]. At this time of human growth an increase in body mass components as well as physical abilities is observed. Still, it is disputable whether this increase results either from training or from biological development. Therefore, testing the balance ought to constitute an inseparable element of properly monitored training. The purpose of this study was to determine the relationship between body composition, aerobic capacity and the body balance in young tennis players at rest and during fatigue triggered by an endurance test. What is more, the aim of the research was to compare two age categories of tennis players and find any correlations between the body balance, time of a repeated specific tennis drill and the tennis ranking position within those groups.

Material and methods

Subjects

Well-trained 16 young tennis players (15 and 17 years old, singles national ranking 3–39, average training experience of 9 years) took part in this study. They were assigned to two groups according to their age – 15 TG and 17 TG (TG – tennis group). The study was performed in a national sport centre during a tennis-camp in autumn-winter period, the pre-season of year-long training. All players had just undergone their medical examinations and brought written consents of their parents to participate in this study as approved by the hosting university's Research Ethics Board. Each participant was subjected to preliminary exercise testing to familiarize themselves with the exercise model and to obtain a measure of their maximal aerobic work capacity. Participants completed the same battery of body composition, aerobic, and body balance assessments. Body balance measurement was repeated twice – before and after the aerobic assessment.

Body composition assessment

Body mass (BM) and body composition were estimated using a multi-frequency bioelectrical impedance analysis (In Body 720, Biospace Analyzer, Korea) [9,10]. These measurements were taken one hour after breakfast and an hour before the physical capacity assessment; the

participants had moved their bladder and bowels prior to the assessment. During the measurement, participants were wearing only briefs and remained barefoot. The analyzer was calibrated prior to each test session. Using a diverse range of frequencies from 1kHz to 1MHz, the InBody720 measured the amount of body water accurately and body composition including fat mass, fat free mass, skeletal muscle mass of each part of the body (right and left arm and leg, trunk).

Aerobic capacity

Aerobic capacity was determined during the $\dot{V}O_{2\max}$ test. Breath-by-breath pulmonary gas exchange was measured (Meta-Max 3B, Cortex, Germany) throughout the test. Participants performed a continuously graded multistage field tennis test according to the protocol suggested by Smekal [11]. The series of 3-minute exercise stages separated by 1-minute breaks for machine adjustments based on typical tennis movements when reaching for a stroke, alternately forehand and backhand, thrown by the ball machine HOT SHOT DXSR-1594. The participants were allowed a 3-min warm-up period before the test. Immediately following the warm-up, the $\dot{V}O_{2\max}$ testing began and continued until the participant reached the point of volitional exhaustion (oxygen uptake does not increase or the frequency of the ball was so high that reaching strokes becomes impossible). The break for machine adjustments between each exercise stage was passive with the participant in a seated position. During the initial phase of exercise the frequency of the ball machine was 8 balls per minute, whereas in the final phase it varied from 22 to 24 balls per minute, according to individual endurance abilities. Additionally, the effectiveness of strokes was established basing on the amount of balls hitting target zones in each stage of exercise. Prior to the beginning of the test by subsequent players the O_2 and CO_2 analyzers were calibrated using standard gases of known concentrations in accordance with manufacturer guidelines. Heart rates (HR) were monitored continuously by telemetry (T 31, Polar Electro-Oy, Finland) during each test session and the first 5 minutes of passive recovery after the whole test. The player and device formation schematics are presented in Figure 1.

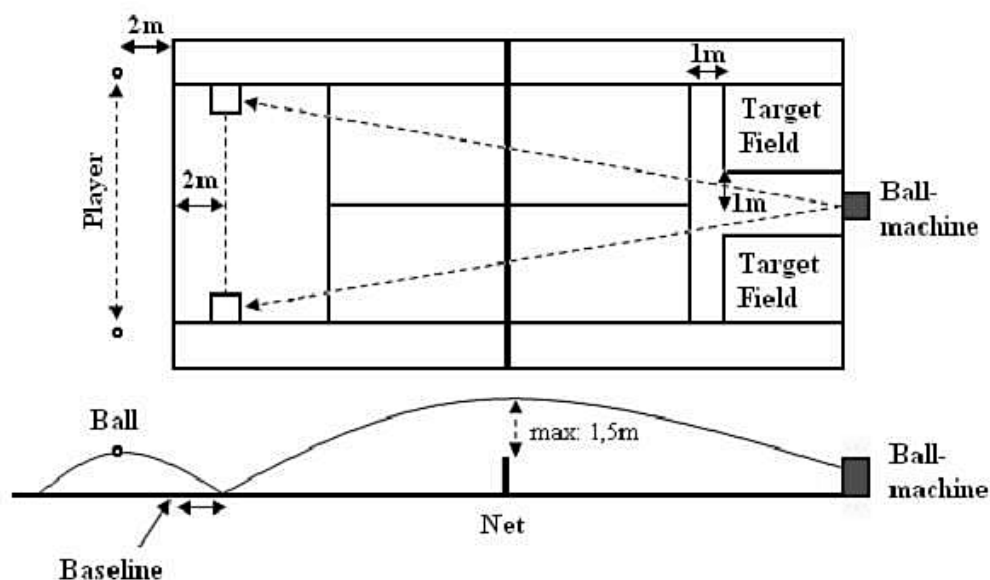

Fig. 1. Test design of the tennis field test

Balance ability assessment

The ability to maintain static balance in a vertical position was measured with a usage of the posturographic method [12]. Examination was held twice – once with eyes opened, and then with eyes closed. A posturograph manufactured by Olton – Poland consisted of a platform of the following dimensions: 400 x 400 x 55 mm, equipped with tensometric detectors, enabling the registration of the position of the vertical projection of the center of mass (COM) – a center of foot pressure (COP). Measurements were taken before and after exercise (with open eyes, with closed eyes and in terms of feedback). The following features were included in the analysis: area developed by COP – COPA expressed in square millimeters [mm²]. The abbreviations used recur throughout the paper.

Tennis ability

In order to determine tennis ability a specific tennis drill (TD) was performed. These movements mimicked those made during a tennis match (run-forehand, run-backhand, run for volley and smash). This exercise was completed as fast as possible with a tennis racquet in hand but without a tennis ball. The player touched each post with the racket before changing a direction and performing the next stroke. The elapsed time was also measured using photoelectric cells (Racetime 2 SF, Microgate) with an accuracy of 0.001 s. The tennis drill was repeated six times with a 30 s break between each trial (Figure 2).

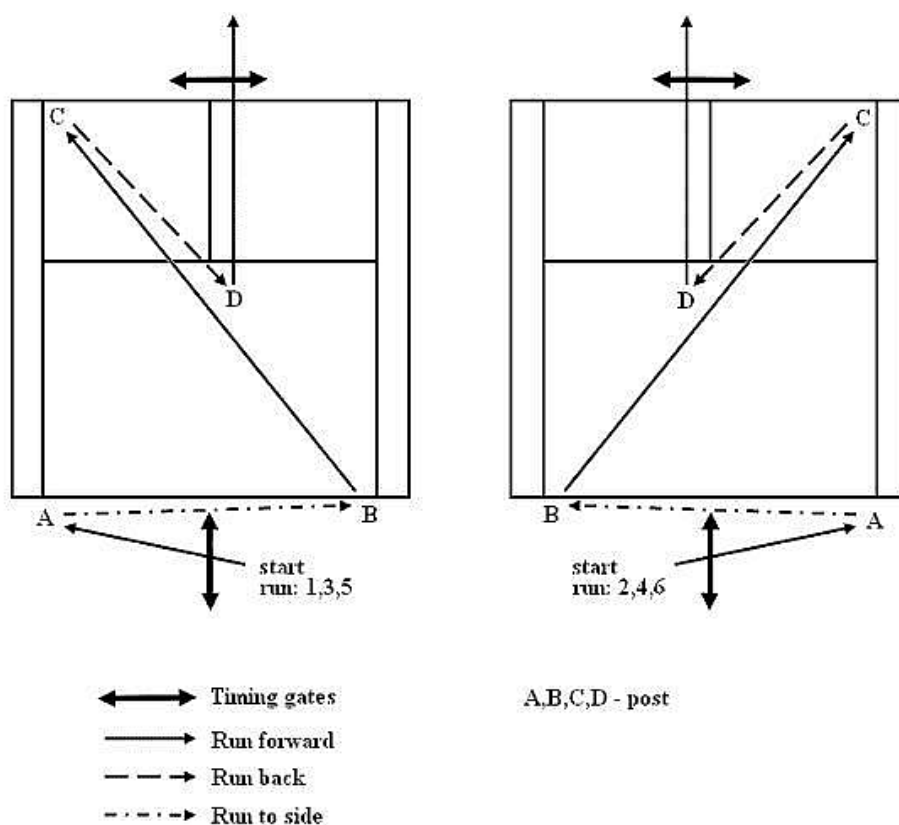

Fig. 2. Test design of the tennis drill test (TD)

Running speed assessment

Players' running speed has been measured in two ways. Measurement of the starting speed was performed during the run over a distance of 5 meters preceded by 0.5 meter running start. The maximal speed was measured similarly, during the run over a distance of 5 meters but this time the

running start was 10 meters long. The elapsed time was also measured using photoelectric cells (Racetime 2 SF, Microgate) with an accuracy of 0.001 s. The test was repeated three times with a 20 s break between runs [13,14].

A statistical analysis was completed using Statistica 8.0 for Windows. T-test was using to determine the differences between groups. Additionally, a 2 (group) x 2 (time) repeated measures analysis of variance (ANOVA) was used to determine the significance of differences between body balance prior to and after the endurance test. Values of motor abilities, anaerobic and aerobic capacity values were subjected to Pearson correlations in order to assess their influence on the ranking position. Statistical significance was set at $p \leq 0.05$ for all analyses.

Results

The anthropometric characteristic of both 15 TG and 17 TG was presented in Tables 1 and 2.

Tab. 1. Participant demographic and anthropometric characteristics

Variable	15 TG n=7	17 TG n=9
Height [cm]	176.5 ± 10.3	182.3 ± 8.50
Weight [kg]	66.0 ± 14.8	68.3 ± 11.2
Biological age height [centile]	74* ± 30	58 ± 33
Biological age weight [centile]	65* ± 40	54 ± 32
FFM [kg]	59.2 ± 11.6	62.5 ± 10.5
Fat [kg]	6.90 ± 3.50	6.10 ± 1.70
Fat [%]	9.70 ± 3.10	8.90 ± 2.10
BMI [kg · m ⁻²]	20.5 ± 2.70	21.3 ± 2.20
WHR	0.79 ± 0.01	0.79 ± 0.02

Values are means ± SD, FFM – fat free mass, Fat – fat mass, Fat % – percentage of body fat, BMI – body mass index, WHR – waist-to-hip ratio. TG – tennis group; the values for groups do not differ significantly, except for biological age, *significant differences ($p \leq 0.05$)

Tab. 2. Values of weight of particular body segments

Variable	15 TG n=7	17 TG n=9
SMM [kg]	33.4 ± 6.94	35.5 ± 6.22
SLM [kg]	55.9 ± 10.9	59.0 ± 9.84
Right arm mass [kg]	3.30 ± 0.77	3.55 ± 0.77
Left arm mass [kg]	3.22 ± 0.81	3.41 ± 0.76
Right leg mass [kg]	9.39 ± 1.82	9.87 ± 1.71
Left leg mass [kg]	9.39 ± 1.79	9.89 ± 1.66
Trunk mass [kg]	26.0 ± 4.81	27.2 ± 4.43

Values are means ± SD, SMM – skeletal muscle mass, SLM – soft lean mass; values are not significantly different for group

No statistically significant differences were noted between particular body mass components. Still, 17 TG was characterized by higher whole body mass, fat free mass and a lower percentage of fat mass. Deviations of standard values of the parameters of the body composition noted within

two groups suggest considerable anthropometric diversity of the subjects. The assessment of the lean body mass of particular body elements may indicate that the 15 TG group has considerably lighter upper limbs and trunks. Still, the younger group is characterized by an accelerated biological age in comparison to the older one. This tendency was observed within 15 TG both regarding weight and height.

Aerobic performance was estimated through the performance of the specific tennis effort of a gradually increasing intensity. Values of the heart rate (Table 3) at the first two stages (played balls frequency – 13 balls · min⁻¹ and 18 balls · min⁻¹, respectively) were quite similar. During the subsequent stages of the test, with an increasing frequency of the played balls, in 15 TG higher values of HR were recorded than in 17 TG. No divergences of average HR were noticed when the frequency of played balls achieved the 7th and 8th stage (played balls frequency – 22 balls · min⁻¹ and 28 balls · min⁻¹ respectively). Nonetheless, the results of HR during the breaks between the subsequent stages of the test were much lower in the 17 TG group. Therefore, it may be concluded that those players undergo recovery processes more efficiently.

Tab. 3. Values of heart rate [HR] during the exercise test at various frequency stages of played balls

Variable	15 TG n=7	17 TG n=9
HR [b·min ⁻¹] Rest	79 ± 5	77 ± 5
HR [b·min ⁻¹] Bn5	154 ± 15	149 ± 11
HR [b·min ⁻¹] End5	167 ± 7	160 ± 10
HR [b·min ⁻¹] Bs5	104 ± 22	100 ± 15
HR [b·min ⁻¹] Bn6	175 ± 7	165 ± 15
HR [b·min ⁻¹] End6	187 ± 5	180 ± 8
HR [b·min ⁻¹] Bs6	117 ± 15	114 ± 18
HR [b·min ⁻¹] Bn7	185 ± 12	183 ± 13
HR [b·min ⁻¹] End7	199 ± 4	203 ± 32
HR [b·min ⁻¹] Bs7	131 ± 9	126 ± 12
HR [b·min ⁻¹] Bn8	190 ± 14	192 ± 11
HR [b·min ⁻¹] End8	198 ± 5	198 ± 6
HR [b·min ⁻¹] Bs8	128 ± 6	121 ± 12
HR [b·min ⁻¹] Aft	121 ± 5	117 ± 13

Values are means ± SD, HR – heart rate, Bn [5,6,7,8] – at the beginning of the tennis field test, End [5,6,7,8] – at the end of the tennis field test, Bs – during brakes [5,6,7,8], Aft – 3 minutes after the tennis field test, [5,6,7,8] – stage of the frequency played balls; values are not significantly different for the group

Throughout all the stages, the oxygen uptake was constantly monitored. The highest values of $\dot{V}O_2$ max were noted in 17 TG, both within absolute and relative values. The level of physical efficiency measured with relative $\dot{V}O_2$ max reached 58.8 mL · kg⁻¹ · min⁻¹ in 15 TG and 63.7 mL · kg⁻¹ · min⁻¹ in 17 TG (Table 4). Differences between the groups were statistically significant. Surprisingly, the effectiveness of tennis strokes corresponding to the highest frequency of played balls was slightly higher in 15 TG in comparison to the latter one. Still, it must be pointed out that not all 15-year-old players managed to complete the stage of the highest intensity corresponding to the frequency of 28 balls · min⁻¹. The majority of those tennis players achieved their $\dot{V}O_2$ max at the penultimate stage of the exercise. In the part of 15 TG that completed the exercise stage of the

highest intensity a strong correlation between the effectiveness of strokes and ranking position was observed ($r = -0.85$).

Tab. 4. Values of oxygen uptake [$\dot{V}O_2$] and the effectiveness of strokes [Ef] during the exercise test at various frequency stages of played balls

Variable	15 TG n=7	17 TG n=9
$\dot{V}O_2$ [mL·kg ⁻¹ ·min ⁻¹] Rest	6.83 ± 1.47	6.70 ± 1.76
$\dot{V}O_2$ [mL·kg ⁻¹ ·min ⁻¹] Bn5	39.8 ± 8.99	41.1 ± 7.45
$\dot{V}O_2$ [mL·kg ⁻¹ ·min ⁻¹] End5	46.5 ± 9.20*	42.9 ± 6.82*
$\dot{V}O_2$ [mL·kg ⁻¹ ·min ⁻¹] Bs5	13.2 ± 5.88	11.1 ± 2.28
Ef [%] 5	72.2 ± 9.97	75.6 ± 12.3
$\dot{V}O_2$ [mL·kg ⁻¹ ·min ⁻¹] Bn6	49.2 ± 6.73	49.2 ± 5.75
$\dot{V}O_2$ [mL·kg ⁻¹ ·min ⁻¹] End6	51.5 ± 7.60	52.3 ± 6.34
$\dot{V}O_2$ [mL·kg ⁻¹ ·min ⁻¹] Bs6	12.7 ± 3.26	12.2 ± 2.44
Ef [%] 6	82.2 ± 5.91	80.3 ± 8.96
$\dot{V}O_2$ [mL·kg ⁻¹ ·min ⁻¹] Bn7	53.2 ± 5.03	55.7 ± 4.11
$\dot{V}O_2$ [mL·kg ⁻¹ ·min ⁻¹] End7	56.8 ± 5.19	59.7 ± 3.83
$\dot{V}O_2$ [mL·kg ⁻¹ ·min ⁻¹] Bs7	16.2 ± 3.25	14.4 ± 2.99
Ef [%] 7	70.2 ± 26.1	78.2 ± 8.50
$\dot{V}O_2$ [mL·kg ⁻¹ ·min ⁻¹] Bn8	55.7 ± 3.78*	59.6 ± 1.78*
$\dot{V}O_2$ [mL·kg ⁻¹ ·min ⁻¹] End8	57.5 ± 3.50*	62.7 ± 4.38*
$\dot{V}O_2$ [mL·kg ⁻¹ ·min ⁻¹] Bs8	18.0 ± 5.32*	20.6 ± 7.05*
Ef [%] 8	41.2 ± 21.2	38.4 ± 17.6
$\dot{V}O_2$ [mL·kg ⁻¹ ·min ⁻¹] Aft	12.5 ± 2.07	13.9 ± 2.07
$\dot{V}O_2$ [mL·kg ⁻¹ ·min ⁻¹] max	58.8 ± 3.31*	63.7 ± 4.27*

Values are means ± SD; $\dot{V}O_2$ – volume of oxygen uptake, Bn [5,6,7,8] – at the beginning of the tennis field test, End [5,6,7,8] – at the end of the tennis field test, Bs – during brakes [5,6,7,8], Aft – 3 minutes after the tennis field test, $\dot{V}O_{2max}$ – maximal oxygen uptake, Ef [%] [5,6,7,8] – Effectiveness of strokes, [5,6,7,8] – stage of the frequency played balls, *statistically significant difference $p \leq 0.05$

Analyzed motor abilities do not suggest any statistically significant differences within two groups (Table 5). However, the starting speed test has proved that 15 TG performed the test faster than 17 TG. The test of 15 TG was completed in 1.037 s, whereas subjects from 17 TG finished it in 1.057 s. Nevertheless, 17 TG obtained better result in the maximal speed (0.0698 s). Still, this value differed from the one recorded in 15 TG by only 0.008 s. According to expectations, 17 TG obtained better time results in the Tennis Drill test (TD). In all repetitions they reached results ranging from 8.742 s to 8.954 s. By contrast, 15 TG always have exceeded the time of 9 s (ranging from 9.134 s to 9.316 s). In 15 TG the correlation between the starting speed and the ranking position was noted. Players who achieved better results in the starting speed were likely to have a better ranking position as well. The analysis of repeated measurements indicates the lack of statistically significant differences (Figure 3). The results obtained in the static balance measurement shows this motor ability to be more developed in 17 TG; however, the disparities between the groups are not statistically significant. Results obtained in the study were analyzed in

terms of determining relations between motor abilities. A statistically significant correlation was observed between the area developed by the center of foot pressure (COPA) and the time of each tennis drill repetition. Particularly strong dependencies were noted in 17 TG. Not only were they more developed, but also had more a considerable impact on the results of TD (Table 7).

Tab. 5. Values of starting and maximal speed

Variable	15 TG n=7	17 TG n=9
Starting speed [s]	1.037 ± 0.056	1.057 ± 0.077
Maximal speed [s]	0.698 ± 0.038	0.690 ± 0.034

Values are means ± SD; values are not significantly different for groups

Tab. 6. Values of area developed by center of foot pressure [COPA] before and after physical effort

Variable	15 TG n=7	17 TG n=9
COPA _{oeb} [mm ²]	1095.67 ± 692.52	963.60 ± 572.60
COPA _{oea} [mm ²]	1120.83 ± 522.22	1572.50 ± 946.75
COPA _{ceb} [mm ²]	1323.50 ± 269.34	989.40 ± 537.96
COPA _{cea} [mm ²]	1634.33 ± 847.21	1423.00 ± 1242.89
COPA _{fb} [mm ²]	762.33 ± 411.23	470.10 ± 247.24
COPA _{fa} [mm ²]	563.66 ± 245.16	438.80 ± 215.19

Values are means ± SD, COPA – area developed by the center of foot pressure, oeb – open eyes before, oea – open eyes after exercise, ceb – closed eyes before, cea – closed eyes after, fb – feedback before, fa – feedback after; values are not significantly different for groups

Tab. 7. Correlation between the body balance and time of each tennis drill [TD] among young tennis players

Balance	group	TD ₁ [s]	TD ₂ [s]	TD ₃ [s]	TD ₄ [s]	TD ₅ [s]	TD ₆ [s]
	17 TG	0.63*	0.75*	0.81*	0.71*	0.67*	0.66*
COPA _{oeb}	15 TG	0.28	0.30	0.45	0.26	0.28	0.42
	WG	0.43	0.57*	0.63*	0.52*	0.48	0.49
COPA _{ceb}	WG	0.57*	0.53*	0.64*	0.52*	0.44	0.41
COPA _{fa}	WG	0.35	0.48	0.60*	0.47	0.42	0.53*

*COPA – area developed by center of foot pressure, oeb – open eyes before, oea – open eyes after exercise, ceb – closed eyes before, fa – feedback after, TG – tennis group, WG – whole tennis group
statistically significant correlations p≤0.05

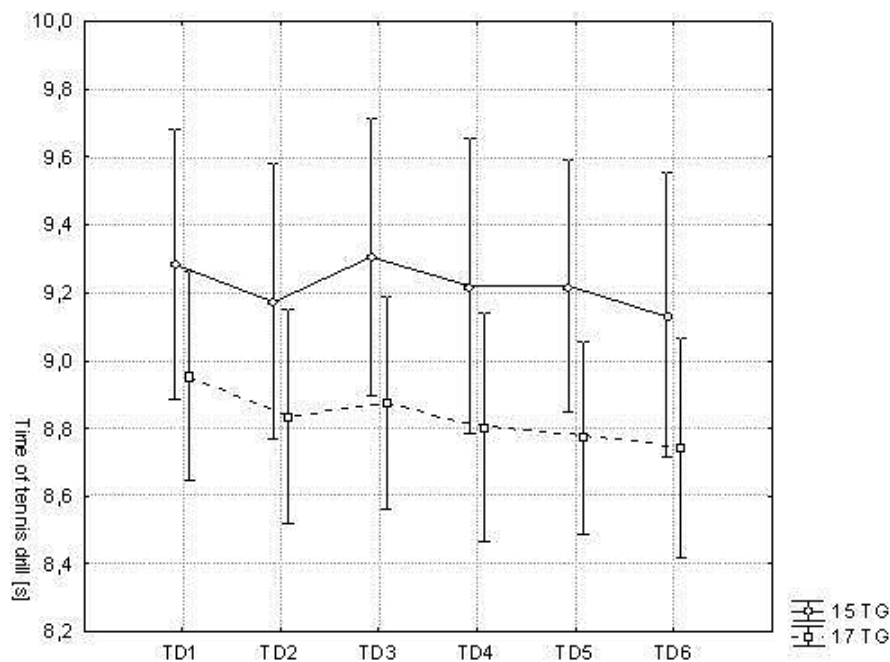

Fig. 3. The average time of each ability tennis drill repetition within two groups

Discussion

The main finding of this study points out to the body balance as being a motor ability influencing results achieved in a specific tennis drill. This connection was observed in both of the tested groups; however, it was particularly significant within 17 TG. Consequently, it may be concluded that those players who have better balance parameters and hence better footwork tend to be more effective during the matches. The values achieved by the older group in all trials (open, closed and feedback) were better than the results recorded in the younger one. However, differences between groups were not statistically significant. In our experiment only 16 tennis players took part; thus the lack of statistical correlation in three different trials may result from a limited subject group. In order to assess the ability to maintain static and dynamic balance, the posturographic method was applied. The area developed by COP constituted the main parameter of the assessment. The smaller the area, the better the result was, and therefore, the posture was claimed to be more stable. Still, the measurements might have been influenced by the post-exercise fatigue, the effectiveness of neural-muscle coordination, the level of motor coordination and concentration. The observed connection may suggested that the engagement of the optical receptor increases the effectiveness of balance. On the other hand, the exercise did not influence considerably the results of maintaining static balance and, more importantly, did not cause their deterioration. The specific ability tennis drill was performed six times with the work to rest ratio being 1:3. Determination of the time of work and rest was based on ITF recommendations, which indicate anaerobic energetic systems as dominating in tennis. The recorded time not only established the movement ability of subjects, but also assessed the effectiveness of the capacity of the anaerobic metabolic system. A better time result achieved during the test was an outcome of the influence of both of the mentioned factors.

Nonetheless, no correlation was observed between the time of the specific tennis drill and a ranking position. Probably, the main reason for the lack of correlation lays in the choice of the subjects – only the best tennis players of each age category took part in the study. Therefore, the diversity of physical abilities was rather limited. The recorded results find confirmation in the

research by other authors. Porada et al. noticed the lack of correlation between a ranking position and the level of motor abilities achieved in a physical fitness test – Eurofit [15]. However, in our study the correlation between the starting speed and a ranking position constituted an exception differing our observation from Porada's research. Such disparity may result from the measurement methods applied by Porada, who used a pendulum run for the assessment of speed. In our opinion, this method evaluates agility rather than speed, due to the constant changes of direction that this method bases on. Therefore, in our study the speed was measured during a straight line run, once from a static start and then from a running position. Measurement was completed with a usage of electric photocells. The applied specific tennis drill in a repetitive version constituted a base for the evaluation of the motor abilities. The other reason which can explain the lack of statistical correlation between time of tennis drill and the ranking position is the biological age of tennis players. In the younger group of athletes it is accelerated, yet in the older one it is no longer so dynamic. Such a tendency may suggest the insufficient body balance training that could have significantly contributed to the older players achieving better results in a tennis drill. Our suggestion confirmed the correlation between the body balance and time of tennis drill both for two age categories and the whole group of subjects.

In this study, the relation between the body composition and a ranking position was investigated. Unexpectedly, such connection was not observed. In order to assess body composition a highly precise method was applied. According to the expectations, the parameters of particular body elements indicate higher skeletal muscle mass in 17 TG. However, a minor disproportion between the muscle mass of upper limbs was noted in comparison to the lower ones. This may indicate the insufficiency of the compensation training. Still, similar to our results were the ones reported by Sanchez et al., who observed the lack of correlation between player's morphological body build and their position in the international ranking of junior tennis players (both male and female) [16]. In his analysis, Sanchez compared body compositions of tennis players, both male and female, participating in the Junior Championships. Similarly to our research, Sanchez also assessed only a group of the best players. Such a selection of subjects by Sanchez could have been the reason for the lack of correlation to occur. It appears to be a confirmation that not only the body mass influences the results achieved in the physical tests but also the metabolic efficiency of skeletal muscle mass. Such a thesis may be supported by the observation made during an aerobic performance assessment, where players characterized by a higher skeletal muscle mass achieved better percentage effectiveness of strokes at the stage of the highest frequency of played balls. Both the amount of the skeletal muscle mass and its metabolic efficiency provided the subjects with a higher oxygen uptake. It also allowed them to approach a ball more quickly and manage to keep up with an increasing intensity of a performed effort, scoring the high percentage effectiveness of strokes. The level of aerobic capacity was considered as satisfactory. Maximal oxygen uptake ranged from 58.0 to 63.0 mL · kg⁻¹ · min⁻¹. Those are the standard values suggested by the International Tennis Federation for this particular age group. The level of aerobic capacity did not, however, correspond to the occupied ranking position [17,18]. Banzer et al. has recorded disparate observations reporting a direct correlation between VO₂max and the ATP ranking [19]. Nevertheless, Banzer's conclusion based on a 7-year analysis of only one player. Unpublished data indicate that VO₂max of a tennis player occupying the first position in the ATP ranking, Rafael Nadal, equals 75 ml · kg⁻¹ · min⁻¹. A high level of $\dot{V}O_2$ max is vital not only during the rallies, but also at rests between them, as it provides more efficient recovery. In our research, within 17 TG more efficient recovery processes were recorded in players characterized by high $\dot{V}O_2$ max. The level of maximal oxygen uptake is one of the main factors determining the style of game: a player withdrawn at a baseline or an aggressive, constantly attacking one. The value of $\dot{V}O_2$ max should be taken into consideration when designing training programmes specifically for different styles of play.

Conclusions

Summing up, the presented study does not point out the main factor to focus on when conducting a career of a professional tennis player regardless of the numerous tests and measurements included in the analysis. The observed interesting correlations may suggest that for the players in a developmental age it is speed and balance that ought to be more intensively developed. Nonetheless, in order for the improvement to take place, methods of evaluation of those motor abilities require standardization. What is more, a systematic control of physical performance can allow verification if a given result has been achieved due to training workload or development age.

Acknowledgements

Funding for this project was provided by the Polish Tennis Association. The authors would like to thank Radosław Szymanik and Henryk Kornas – Polish National Team coaches for help in holding the research and the players for their engagement in the performance of the imposed training program.

References

1. Perkins RH, Davis D. Musculoskeletal injuries in tennis. *Phys Med Rehabil Clin North Am* 2006;17:609-631.
2. Babette P, Miller S, Dines , et al. Sport science and medicine in tennis. *Br J Sport Med* 2007;41:703.
3. Jarocki A, Markiewicz G, Starosta W. Selected elements of movement co-ordination as affected by prolonged training loads in tennis at high ambient temperature. *Medycyna Sportowa* 2001;17(115):67-70.
4. Malliou VJ, Beneka GA, Gioftsidou AF, et al. Young tennis players and balance performance. *J Strength Cond Res* 2010;24(2):389.
5. Malliou VJ, Vasiliki J, Malliou P, et al. Balance exercise program before or after a tennis training session? *J Back Musculoskeletal Rehabil* 2008;21(2):87.
6. Petersen C. Fit to play – tennis. *Sport Ex Dynamics* 2006;8:9-13.
7. Psalman V. Dynamic balance and its diagnostics by using 3D biomechanical analysis. *Facta Universitatis: Series Physical Education & Sport* 2008;6 2:105-109.
8. Filipčič A, Filipčič T. The relationship of tennis-specific motor abilities and the competition efficiency young female tennis players. *Kinesiology* 2005;37(2):164-172.
9. Portao J, Bescós R, Irurtia A, Cacciatori E, Vallejo L. Assessment of body fat in physically active young people: anthropometry vs bioimpedance. *Nutr Hosp* 2009;Sep-Oct;24(5):529-34.
10. Lim JS, Hwang JS, Lee JA, et al. Cross-calibration of multi-frequency bioelectrical impedance analysis with eight-point tactile electrodes and dual-energy X-ray absorptiometry for assessment of body composition in healthy children aged 6-18 years. *Pediatr Int* 2009;Apr;51(2):263-8.
11. Smekal G, Pokan R, von Duvillard SP, Baron R, Tschan H, Bachl N. Comparison of Laboratory and “On-Court” Endurance Testing in Tennis. *Int J Sports Med* 2000;21:242-249.
12. Żurek P, Rynkiewicz M, Rynkiewicz T, Kos H. The level of the ability to maintain static balance in competitors of cyclic sport at the stage of directed training. *Studies in Physical Culture and Tourism* 2010, in press.
13. Ziemann E, Garsztka T. Body composition and anaerobic performance in young tennis players. In: Miller S, Capel-Davis J, editors. *Tennis science and technology. Ed. 3*. London: International Tennis Federation, 2007; 145-151.
14. Ziemann E, Garsztka T. Anaerobic performance during intermittent exercise and body composition in tennis players of different biological and chronological ages. In: Lees A, Carbello D, Torres G, editors. *Science and Racket Sports IV*. Oxon: Routledge, 2009; 22-28.
15. Porada K, Kruczyński J, Zieliński W. Dynamika zmian sprawności fizycznej zawodników w tenisie [Dynamics of changes physical fitness in tennis players]. *Medycyna Sportowa* 2007;2(6):106-112.
16. Sánchez-Muñoz C, Sanz D, Zabala M. Anthropometric characteristics, body composition and somatotype of elite junior tennis players. *Br J Sports Med* 2007;41:793-799.
17. Crespo M, Miley D. International Tennis Federation Advanced Coaches Manuals. London: International Tennis Federation, 1998.
18. Kovacs MS. Tennis physiology: training the competitive athlete. *Sports Med* 2007;37(3):189-98.
19. Banzer W, Thiel C, Rosenhagen A, Vogt L. Tennis ranking related to exercise capacity. *Br J Sports Med* 2008;42:152-154.